

UNLESS OTHERWISE SPECIFIED
 DIMENSIONS ARE IN INCHES
 SURFACE FINISH:
 REMOVED ALL BURRS
 AND SHAPP EDGES
 SURFACE ROUGHNESS

25 ✓

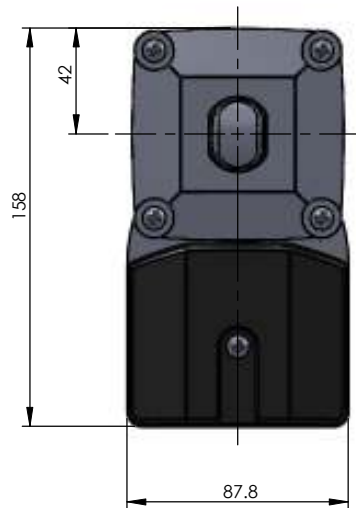
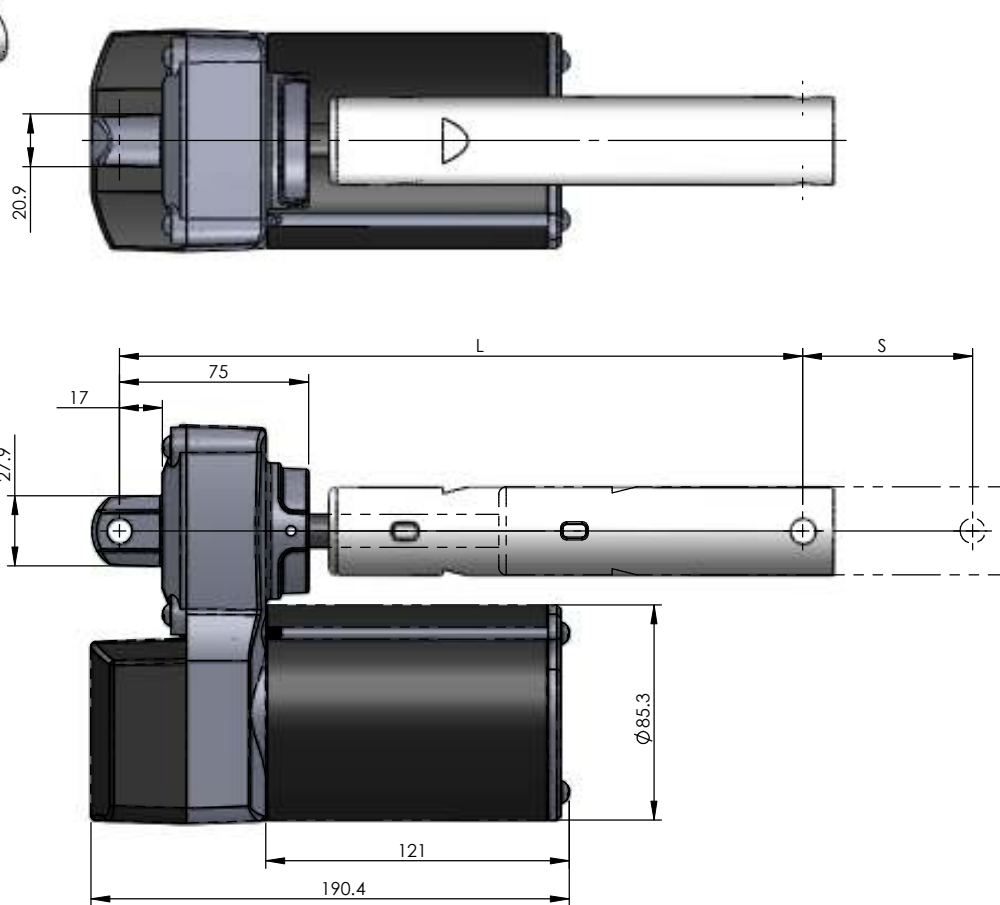
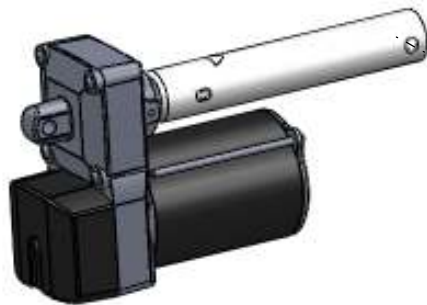
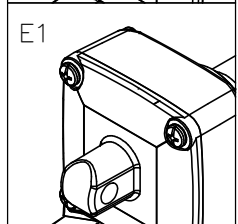
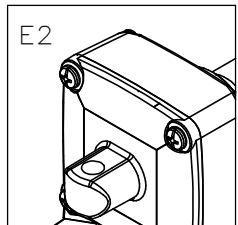
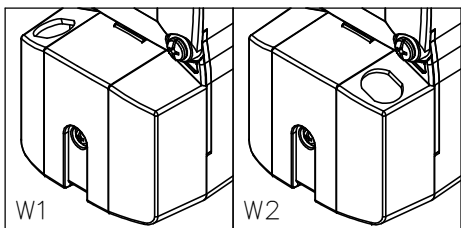

CONFIDENTIAL AND PROPRIETARY				JS35		PART NO.											
THIS IS THE PROPERTY OF ADACEL. IT MUST NOT BE TRADED OR REPRODUCED IN ANY MANNER. NOR SHALL IT BE SUBMITTED TO OUTSIDE PARTIES FOR EXAMINATION WITHOUT OUR CONSENT. IT SHALL BE USED AS A MEANS OF REFERENCE TO DO WORK DESIGNED OR FURNISHED BY US.				PART NAME		AC MOTOR		WEIGHT		6		REV.					
				DESIGN		Q. A.		MATERIAL		QUANTITY		1		SHEET 1 OF 1			
				CHECK		APP'D				SCALE		1 : 10					
						DATE										UNLESS OTHERWISE SPECIFIED TOLERANCES ARE: LENGTH 0-2 ±0.2 2-5 ±0.5 5-12 ±0.75 >12 ±1 HOLE/SHAFT	
						Adacel Technologies Ltd. Shanghai Manufacturing Center Tel: +86-512-82757188 E-mail: info@adaceltech.com											